

Bürstenlose, hochdynamische Servomotore

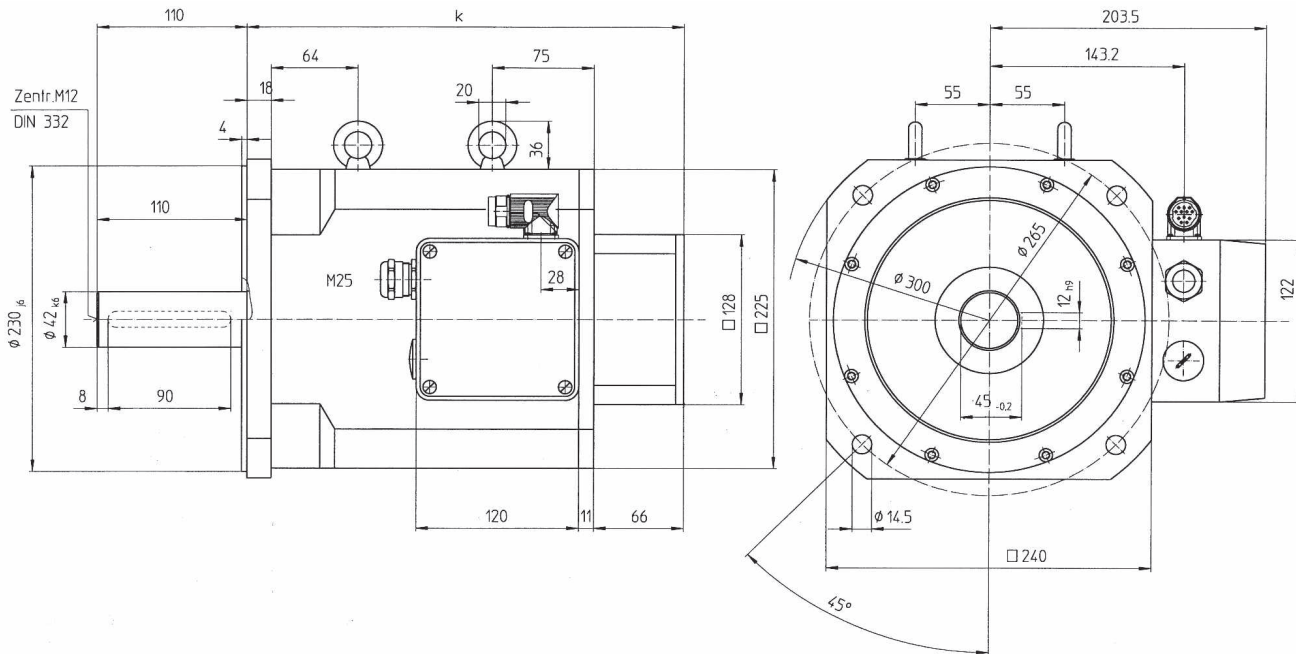

Typ	mit Resolver	mit Resolver und Bremse	mit Drehgeber	mit Drehgeber und Bremse
	k	k	k	k
ISK 7616...	379	446	390	458
ISK 7623...	446	514	458	526
ISK 7630...	514	582	526	594

Technische Daten

ISK	Nennspannung	Nenn-drehzahl	Nenn-leistung	Nenn-moment	Nenn-strom	EMK-konstante	Drehmoment-konstante	Stillstands-moment	Stillstands-strom	Spitzen-moment	Spitzen-strom	Gewicht
	U_N (V)	n_N (min ⁻¹)	P_N (kW)	M_N (Nm)	I_N (A)	K_E (V/1000 min ⁻¹)*	K_T (Nm/A)	M_0 (Nm)**	I_0 (A)**	M_{max} (Nm)***	I_{max} (A)***	m_{mot} (kg)
7616.20/400	400	2000	11,72	56,0	22,0	182	2,54	68,0	22,5	204	87,9	56,0
7623.20/400	400	2000	14,65	70,0	25,3	191,5	2,76	93,0	29,4	279	114,5	73,0
7630.30/400	400	3000	15,7	50,0	29,3	124	1,70	115	55,9	345	219	89,0

* Werte bei 20°C

** Werte bei 200 min⁻¹

*** Kurzzeitbetrieb 30 Sekunden

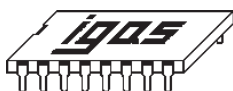

ISK 7616.20/400

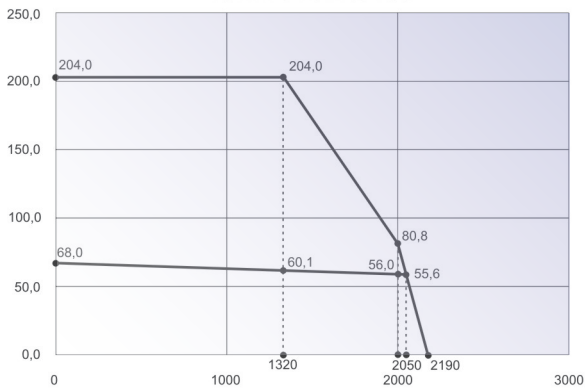

ISK 7623.20/400

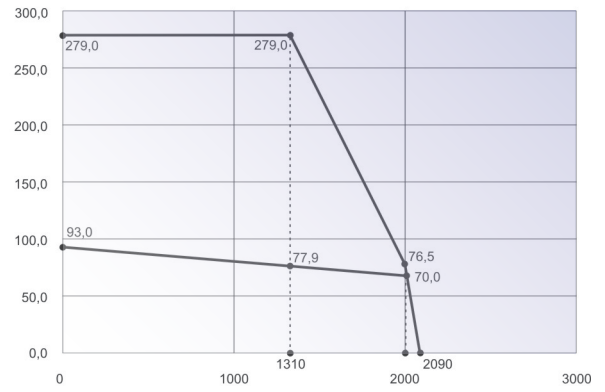

ISK 7630.30/400

